

# NUTS *Nylon Insert (Elastic) Stop Nuts*

Heavy Hex,  
Full Height

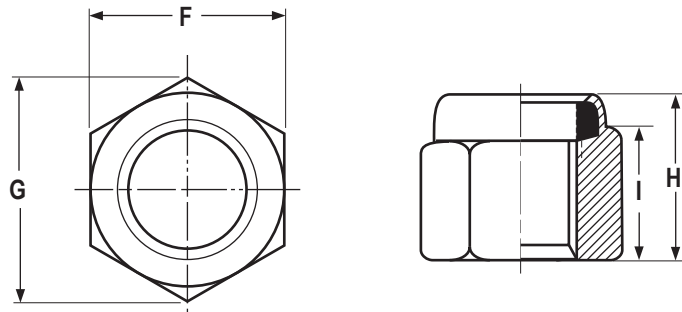

## NYLON INSERT STOP NUTS, HEAVY HEX, FULL HEIGHT

Esna<sup>®</sup>

Nominal Size or Basic Thread Diameter		Esna <sup>®</sup> Part Numbers	F		H		I	G
		Steel, Zinc-plate	Width Across Flats		Thickness		Side Height	Width Across Corners
		Coarse	Max	Min	Max	Min	Ref	Ref
1/4	0.2500	21NU-040	0.503	0.489	0.390	0.360	0.290	0.556
5/16	0.3125	21NU-058	0.566	0.551	0.453	0.423	0.335	0.624
3/8	0.3750	21NU-066	0.691	0.675	0.562	0.532	0.392	0.763
7/16	0.4375	21NU-074	0.754	0.736	0.609	0.579	0.464	0.829
1/2	0.5000	21NU-083	0.879	0.861	0.718	0.688	0.544	0.969
5/8	0.6250	21NU-101	1.067	1.045	0.874	0.844	0.677	1.175
3/4	0.7500	41NU-120	1.255	1.231	1.015	0.985	0.790	1.382
7/8	0.8750	41NU-149	1.444	1.417	1.140	1.110	0.883	1.589
1	1.0000	41NU-168	1.632	1.602	1.312	1.250	1.000	1.796
1 1/4	1.2500	41NU-207	2.008	1.973	1.672	1.610	1.250	2.209
1 1/2	1.5000	41NU-246	2.384	2.344	1.953	1.891	1.413	2.622
1 5/8	1.6250	-	2.572	2.530	2.172	2.110	1.637	2.886
1 3/4	1.7500	41NU-285	2.762	2.715	2.376	2.250	1.830	3.035
2	2.0000	41NU-324	3.137	3.086	2.469	2.343	1.750	3.449
2 1/4	2.2500	-	3.514	3.457	2.876	2.750	2.063	3.862

Specifications for 1.625 and 2.25" nominal sizes are independent of Esna<sup>®</sup> specifications.

Description	Heavy hex nut with a nylon-filled collar at its back end. When the cap-screw or bolt reaches the collar, the threads and nylon form a tight, frictional fit, restricting movement of the cap-screw or bolt when it is subjected to vibration. The nylon insert comes in various colors.
Applications/ Advantages	Has greater surface area than NM-series nuts, making wrenching easier. Designed to be used with cap-screws and bolts which have a minimum tensile strength not greater than 90,000 psi.. Used in bridge and building construction, material handling, heavy equipment and oil field machinery. Steel nylon insert stop nuts are less expensive than grade-C automation lock nuts. Nylon insert nuts are not designed to be used at temperatures over 250° F.
Material	<i>1/4" through 5/8"</i> -- AISI 1008 - 1010 or equivalent steel; <i>3/4 through 1"</i> -- AISI C1117 or equivalent steel.
Hardness	Rockwell C 28 maximum
Proof Load	90,000 psi.